

## Material moisture

for planiform products  
static and traversing measuring heads

**AF · RF**  
**MP 120**

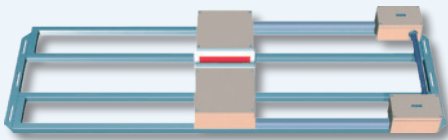

Material moisture AF 120 · RF 120



PLEVA evaluation box MW B



Application moisture



Residual moisture

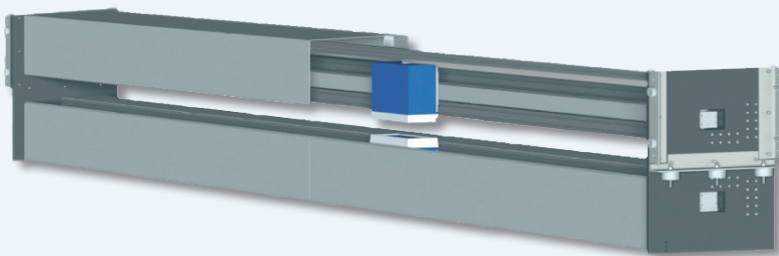

Material moisture profile MP 120



Coating

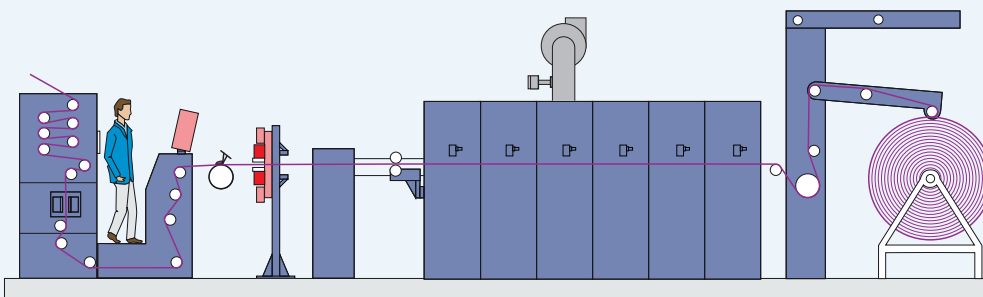

**Material moisture line**

**Moisture measurement static**

Type AF 120  
Type RF 120

**FEATURES OF PRODUCT**

- Measurement is contact-free
- Measuring non hazardous
- Wide measuring range
- Highly accurate measurement
- Large distance between measuring heads up to 110 mm
- Large measuring area 250 mm wide

**Applications of static microwave heads**

PLEVA material moisture measuring units incorporating microwave technology are used to make on-line, contactfree, immediate, precise and non-destructive measuring of the moisture in planiform product. The measuring devices AF • RF are designed for the measurement of application of moisture on webs with fixed measuring heads. Fields of application are:

**Textile industry**

- Liquor pick-up on fabric webs
- Dyeings and wet-in-wet applications independent from sort of fibres and colour
- Latex- and foam-coating for carpets
- Applications at non wovens
- Filters
- Moisture at felts
- Water based coatings
- Minimal applications
- Tyre cords

**Non-textile industries**

- Paper, cardboard
- Adhesives
- Veneer panels
- Laminate boards
- Pluster boards
- Building boards
- Sausage casings
- Medical sector

**BENEFIT FOR CUSTOMER**

- Easy operation
- Requires no maintenance
- Short payback time

**Sensor principle**

Measurement of the material moisture is based on microwave absorption by water. A semiconductor oscillator transmits microwave energy through the web. The non-absorbed part of the energy is received

on the opposite side by a microwave receiver. The amount of absorption is a measurement of the absolute moisture content.

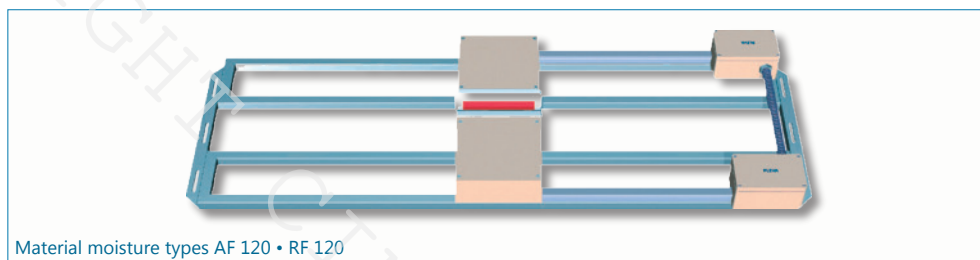

Material moisture types AF 120 • RF 120

**Microwave sensor types static**

**AF 120** with 1 pair of measuring heads:

Measuring range 0 .. 2000 g H<sub>2</sub>O/m<sup>2</sup>

**RF 120** with 1 pair of measuring heads:

Measuring range 0 .. 200 g H<sub>2</sub>O/m<sup>2</sup>

Type A for measurement on cold webs max. 50 °C with active heads

Type P for measurement on hot webs max. 100 °C with passive heads

**PLEVA MW B evaluation electronic box**

The new PLEVA Process box MWB is designed to connect the microwave sensor equipment and to use calibration curves for the different measuring ranges into moisture in gH<sub>2</sub>O/m<sup>2</sup> with automatic optimization of the range.

The box is equipped with display and keypad to adjust the measuring ranges and to select the type of interface for visualization PLEVATEC and others.

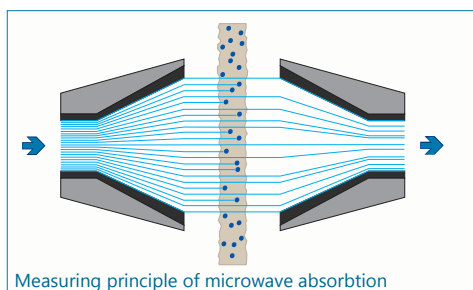

Measuring principle of microwave absorption



Evaluation electronic box MW B for microwave sensors

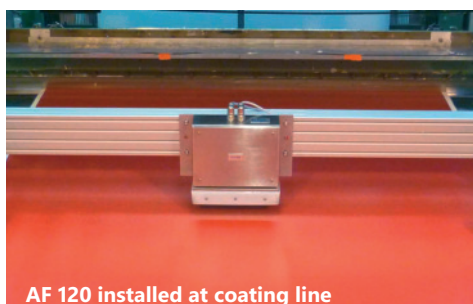

AF 120 installed at coating line

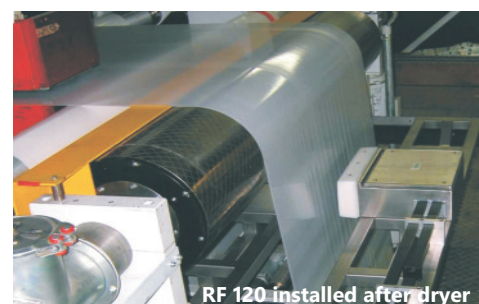

RF 120 installed after dryer

**Moisture measurement traversing**

**Material moisture profile**

**Application of traversing microwave heads**

The traversing moisture measuring units with microwave technology are used to make measurements of the moisture across the width in planiform products webs. The measuring device MP 120 is working in traversing mode continuously or with predetermined positions over the fabric width.

The traversing microwave measurement technique can be used in a large field of application for textile, non-woven, carpet, foil, paper, cardboard, wood, building board, etc.

**Microwave moisture profile MP 120 traversing**

MP 120 with 1 pair of traversing heads:

- Measuring range 0 .. 2000gH<sub>2</sub>O/m<sup>2</sup>
- Measurement on cold webs, max. 50 °C
- Working width 2000 mm up to 5200 mm
- Fabric running horizontal or vertical
- Automatic zero point check
- Automatic adaption to the product width
- Continuous traversing or predetermined positions
- Adjustable traversing speed
- Variable adjustable measuring points over width

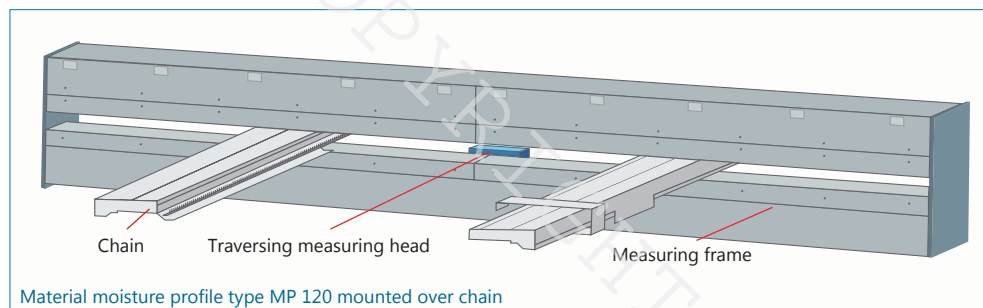

Material moisture profile type MP 120 mounted over chain

**Process control system for MP 120**

The visualization and control for the MP 120 are integrated in a protective stand cabinet.

**Traversing control for MP 120**

For the traversing system MP 120 a PLC is used, which is built together with a servo inverter in the cabinet.



Visualization and protective cabinet

**Visualization PLEVATEC**

The industrial PC panels are equipped with latest state of touchscreen technology. All informations are visible at a glance and the operation is simple and user friendly.

Several versions of software are available for the PLEVATEC visualization for monitoring and control, modular software functions such as, tolerance monitoring, trend as well production report.

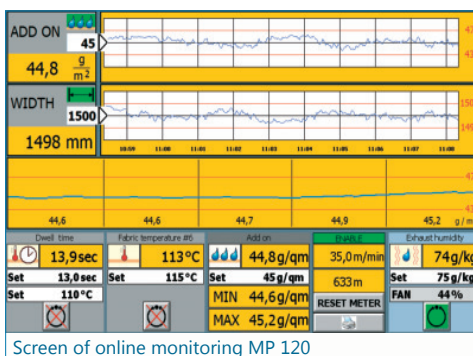

Screen of online monitoring MP 120

Type MP 120

**FEATURES OF PRODUCT**

- Web can pass horizontal or vertical
- Large distance 60 mm between the measuring heads
- Automatic adaption to the product width
- Automatic zero point check
- Measurement in traversing mode or in position mode
- Highly accurate measurement

**BENEFIT FOR CUSTOMER**

- Complete quality control
- Tolerance control of production specifications
- Minimal calibration effort



MP 120 traversing microwave measurement installed at coating line in front of a stenter

# AF • RF MP 120

## Microwave sensors static

Type AF 120 • RF 120

## Technical Data

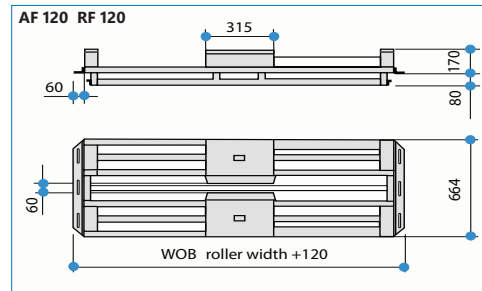

### Sensor AF 120 • RF 120

Ambient temperature sensor: max. 50 °C  
 Temperature of webs: for type A: max. 50 °C  
 for type B: max. 100 °C  
 Measuring range AF 120: 0 .. 2000 g H<sub>2</sub>O/m<sup>2</sup>  
 RF 120: 0 .. 200 g H<sub>2</sub>O/m<sup>2</sup>  
 (using calibration curve)  
 Measurement accuracy: +/- 1 % of measuring range  
 not better than  
 Adjustment time: +/- 0.3 g H<sub>2</sub>O/m<sup>2</sup> absolute  
 inertia free  
 Frame dimension for: fabric width up to 5500 mm  
 Weight approx.: 70 kg (frame width 2000 mm)

## Microwave evaluation electronic

Type MW B

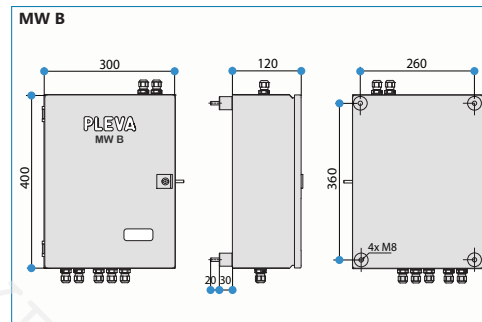

### Electronic Box MW B

Sensors maximal one set of: AF120•RF120  
 Ambient temperature: max. 50 °C  
 Power supply: 24V DC (+/- 10%)  
 Power consumption: 50 VA  
 Current: 2.0 Amps  
 Communication: RS485 serial  
 Protocols: PLEVA, MININET  
 Option: CAN-Bus  
 Analogue outputs: 3 signals 0/4 .. 20mA  
 (isolated)  
 Weight approx.: 10 kg

## Microwave sensor traversing

Type MP 120

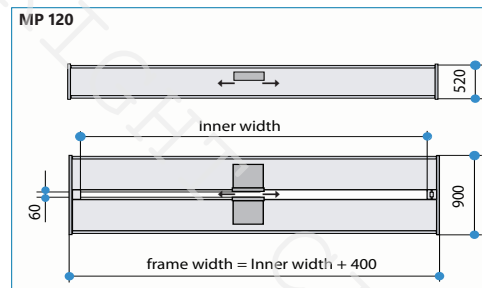

### Sensor traversing MP 120

Ambient temperature sensor: Type MP 120 max. 50 °C  
 Temperature of webs: max. 50 °C  
 Measuring range MP 120: 0 .. 2000 g H<sub>2</sub>O/m<sup>2</sup>  
 (using calibration curve)  
 Measurement accuracy: +/- 1 % of measuring range  
 not better than  
 Adjustment time: +/- 0.8 g H<sub>2</sub>O/m<sup>2</sup> absolute  
 inertia free  
 Frame dimension for: fabric width up to 5200 mm

## Visualization and control

Type PLEVATEC

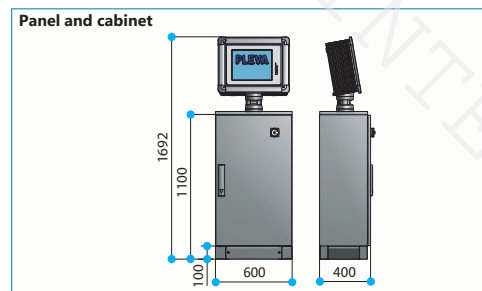

### Accessories optional

- **Visualization PLEVATEC** for front panel mounting
- **Protective cabinet** for visualization and mounting plate
- **Control package** for vacuum slot
- **Control package** for S-roller
- **Special holder** for measuring frame

## PLEVA

Headquarter and Manufacturing:

Rudolf-Diesel-Str. 2  
 D-72186 Empfingen-Germany  
 Tel: +49 (0) 7485 1004  
 Fax: +49 (0) 7485 1009  
 E-mail: info@pleva.org  
 www.pleva.org



## CINTEX

PLEVA Sales and Support in ASIA:

CINTEX AG Hauptstrasse 58  
 CH-8274 Tägerwilien-Switzerland  
 Tel: +41 71 667 02 50  
 Fax: +41 71 667 02 51  
 E-mail: info@cintex.ch  
 www.cintex.ch www.pleva.ch



### Available monitoring and control systems for different applications

- **CIMATIC Touch panels** PP70 • PP100 • PP150 PC based, with separate PLC and standard software.
- **PLEVATEC Touch panels** PC based, with separate PLC and modular software for special applications.
- **ECO-OPTIDRY®** with energy consumption meter for drying process
- **Add'nDry** for coating process
- **PadderControl** for continuous dyeing process
- **SizeControl** for controlled size pick-up
- **DensityControl** for pick/course density
- **StraightLiner** for automatic straightening and distortion analysis
- **StructureDetector** for distortion analysis