

## Control of Drying Cylinders

Controlled drying level  
Optimised heating performance



Infrared temperature sensor



Infrared temperature sensor



Residual moisture RR



CIMATIC DrumDry Control



Condensate temperature



Residual moisture

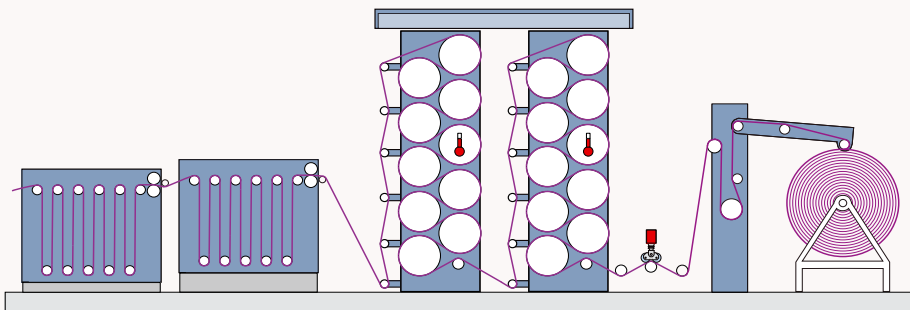

Type DrumDry Control CIMATIC

### FEATURES OF PRODUCT

- Uniform guided drying process
- Retrofit package for sustainable cost reduction for old and new machines
- Easy handling for operators

### Economic Control of Drying Cylinders

The drying based on contact drying (drying cylinders) is probably the most wasteful drying process for textile webs. This fact is based on observations from practice worldwide. Due to process technological reasons most of the dryers are running on an „Uncontrolled Over Drying Strategy“ which leads to extremely high energy costs in comparison to the theoretically needed energy amount to evaporate the water on the fabric.



DrumDry Control CIMATIC touch screen panel

### CIMATIC Cylinder Dryer Control

The CIMATIC DrumDry Control is equipped with new software for cylinder dryer to control the drying process by varying the steam valve position in accordance to the condensate temperature of the dry cans and depending of the residual fabric moisture at the outlet.

The drying level is measured with the residual moisture measurement type RR, with 1 or 3 piece of tandem roller installed after the last stack of the drying cylinder.

This is the best solution for minimum energy consumption, maximum productivity and best quality of drying.

### Control conception

Two overlapping control loops are used to control the cylinder dryer steam valves. The required energy need is regulated as a function of the condensate temperature by controlling the continuous steam valves.

The desired degree of drying is determined with the residual moisture measurement and acts as a overlapping control loop on the set value of the last steam valve. Set values for different fabrics can be stored in recipes.

### BENEFIT FOR CUSTOMER

- Significant energy saving
- Productivity increase
- Improved process reproducibility
- Short payback time

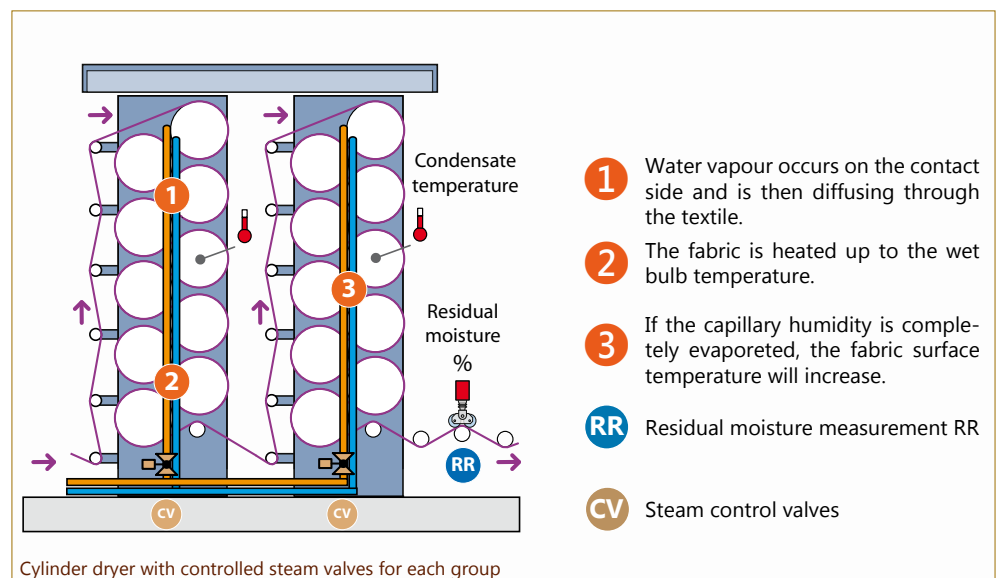

Cylinder dryer with controlled steam valves for each group



DrumDry Control at inlet of a washing range



Continues washing range with cylinder dryer

### Controller and Components

#### CIMATIC Control cabinet Type PP70-G

Modern colour graphic operating panel with modular PLC system and advanced control software for cylinder dryers.

The control system use a touch screen panel with trend graphic display, data gatering, recipe memory for process set values of different kind of fabric and interfaces to connect to network by Ethernet.



Control cabinet PP70-G

#### Temperature sensors Type IR-LT

Temperature sensors are used to measure the condensate temperature of the cylinder dryer stacks.

This information is used to control continuous the steam valves position of each cylinder group for the basic energy demand for drying.



Temperature sensor IR-LT

#### Residual moisture measurement Type RR3.1

The RR with 3 set of tandem roller sensors is based on measurement of the electrical resistance.

The type RR3.1 measures the maximum moisture value of 3 tandem roller sensors in percentage (side/centre/side) and is installed at the outlet of the last cylinder stack.

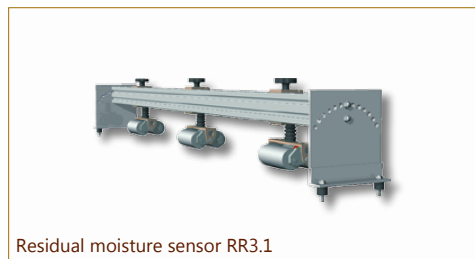

Residual moisture sensor RR3.1

#### Steam control valve Type 3321-E3

Steam control valve with electric actuator for positioning, input signal 0..10V DC or 0(4)..20 mA.



Steam control valve

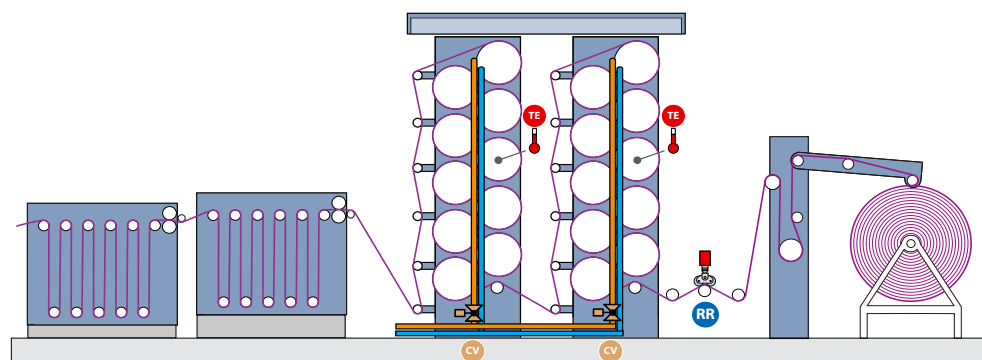

Cylinder dryer with control of condensate temperature and residual moisture for economic drying process



Dry cans coated with regulating valve

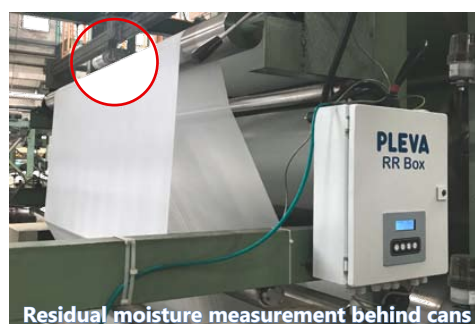

Residual moisture measurement behind cans

### Sensors

#### FEATURES OF PRODUCTS

- Proven control system
- Accurate and reliable measuring technology
- Residual moisture measurement for natural fibres and blends with synthetics
- Brand valves for steam

#### BENEFIT FOR CUSTOMER

- Economical price for control and sensor package
- High product quality by constant drying level
- Optimised energy consumption

# DrumDry Control

## CIMATIC

### DrumDry Control

Type CIMATIC

### Technical Data

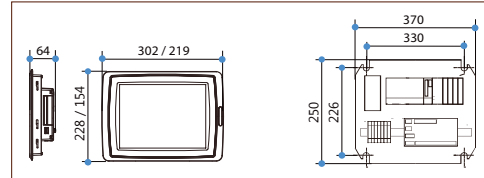
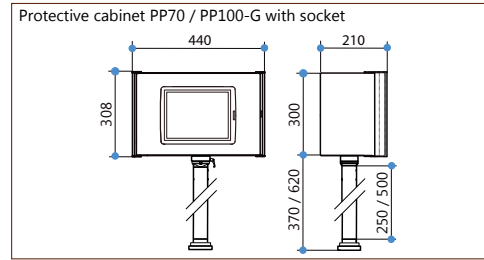

#### DrumDry Control system

Ambient temperature: max. 50 °C  
 Power supply: 230 V AC (+/- 10 %), 50/60Hz  
 Power consumption: approx. 130 VA

Panel type PP 70: 6.5" Touch Screen coloured  
 Panel type PP 100: 10.4" Touch Screen coloured

Weight protective cabinet: 15 kg (wall mounting)  
 Weight stand socket: 2.8 kg (length 250mm)

Panel PP70-R / PP100-R with mounting plate and PLC only

Weight PP70 panel: 1.6 kg  
 Weight PP100 panel: 2.8 kg  
 Weight mounting plate: 4.0 kg

### Temperature sensors

Type IR-LT

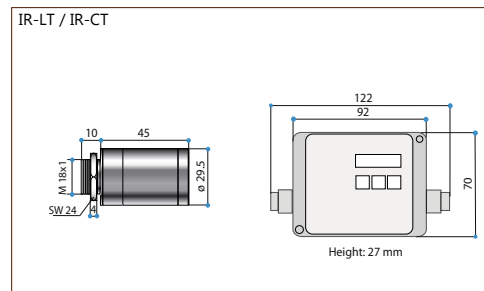

#### Sensor IR-LT / Electronic IR-CT

Ambient temperature sensor max. 85 °C

Measuring range IR-LT: -20 .. 250 °C  
 Measuring distance: 20 .. 800 mm  
 System accuracy: ±1 % of range or ±1,5 °C  
 Reproducibility: ±0.5 % of range or ±0,5 °C  
 Adjustment time: 100 ms  
 Relative humidity: 10 - 95%, non condensing  
 Electronics:  
 Power supply: 8..36 V DC  
 Power consumption: max. 100 mA

### Residual moisture sensor

Type RR 3.3 • RR 3.1 • RR 1.1  
 with side plates and frame

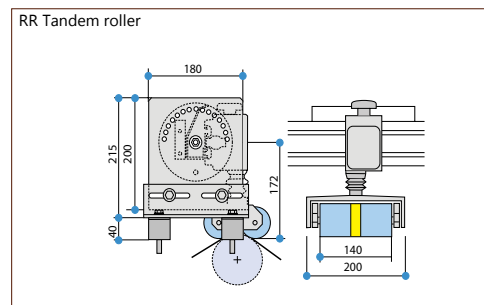

#### Sensor RR Tandem roller

Ambient temperature: max. 100 °C  
 Measuring frame/roller: max. 50 °C  
 Electronic preamplifier box: max. 50 °C  
 Measuring range sensor RR: 0.9 .. 15 % at Cotton  
 0.1 .. 5 % at Synthetics  
 0.2 .. 9 % at Polyamide  
 1.7 .. 30 % at Viscose  
 Power supply: 24 V DC (+/- 10 %)  
 Power consumption: approx. 15 VA, 0.7 Amps.  
 Weight sensor RR1 with swing out unit: approx. 14 kg  
 Electronic Box RR1: approx. 9 kg

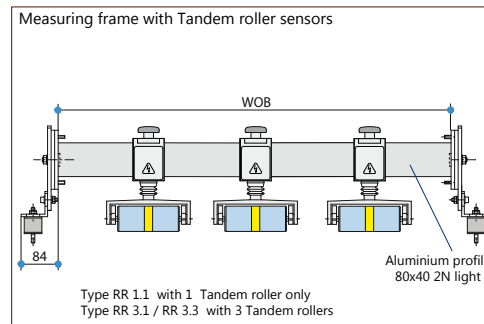

#### Measuring frame with Tandem roller sensors

Type RR 1.1: 1 Tandem roller sensor  
 1 HIMA8 preamplifier  
 Type RR 3.1: 3 Tandem roller sensors  
 1 HIMA8 preamplifier  
 Type RR 3.3: 3 Tandem roller sensors  
 3 HIMA8 preamplifier  
 Side plates for mounting: with swing out unit  
 Frame construction: made of aluminium  
 Frame dimension standard: width up to 2790 mm,  
 wider frame width available up to 6000 mm

### Accessories optional

- **Steam control valves** with electrical actuators and different nominal widths on request
- **Measuring data evaluation** at external PC (data transfer by USB stick or Ethernet LAN)

### Available monitoring and control systems for different applications

- **ECO-OPTIDRY®** with energy consumption meter for drying process
- **Add'nDry** for coating process
- **PadderControl** for continuous dyeing process
- **SizeControl** for controlled size pick-up
- **DensityControl** for pick/course density
- **StraightLiner** for automatic straightening and distortion analysis
- **StructureDetector** for distortion analysis

**CINTEX**  
 TEXTILE AUTOMATION

PLEVA Sales and Support in ASIA:

CINTEX AG Hauptstrasse 58  
 CH-8274 Tägerwilen-Switzerland  
 Tel: +41 71 667 02 50  
 Fax: +41 71 667 02 51  
 E-mail: info@cintex.ch  
 www.cintex.ch www.pleva.ch

